



VOLVO
S60 POLESTAR



WE'RE POLESTAR

*"...the goal is always the same-
To deliver best possible results.
No matter what."*

Polestar is defined by an ambition to be among the top contenders in world motorsport and to bring forward the strength and agility inherent in Volvo cars. Whether it's winning championships, or developing performance cars, the goal is always the same - To deliver best possible results. No matter what.

Contents

WHEN DRIVING
MATTERS | 02

ALL ROADS &
CONDITIONS | 04

MEET THE POLESTAR
VOLVOS | 06

LEARNINGS FROM
THE RACE TRACK | 09

INTELLISAFE | 10

SENSUS | 12

SUSTAINABLE
DRIVING | 15

EXTERIOR | 17

RIMS | 18

COLOURS | 19

INTERIOR | 21

FACTS & FIGURES | 22



WHEN DRIVING MATTERS

“All Polestar products are developed for people like us – who appreciate driving with full control.”

Polestar is about motorsport, and motorsport is about driving. That's why we focus on one thing only – optimising driveability. A Polestar vehicle – be it a race car or road car – is always designed to deliver optimal

grip and control. The race track and open road may be far apart, but both are equally demanding. Regardless of surface or purpose, optimal driveability is what makes a driver feel safe and confident behind the

wheel. All Polestar products are developed for people like us – who appreciate driving with full control.

In other words, when driving matters.



ALL ROADS, ALL CONDITIONS, ALL YEAR ROUND.

“In our minds, this is the optimal performance car.”

A performance car is by definition a fine-tuned instrument, where every component has the purpose of maximising driveability and control, ensuring both an exciting and safe drive.

The S60 Polestar is the result of nearly two decades of racing experience and know-how from exploring the limits of Volvo cars. Together with Volvo's own engineers and their expertise of building

cars for the open road, we have developed a performance car for real life. A car that performs on all roads, in all conditions, all year round. In our minds, this is the optimal performance car.



The best way to experience the driveability and control of the S60 Polestar is to go for a test drive.



MEET THE POLESTAR VOLVO

*“A performance car for real life.
Not only for that perfect sunny Sunday.”*

Building a race car with the only aim to be as fast as possible on the track is one thing. Developing a road car with optimal driveability for all conditions and all roads, is a completely different challenge. The key to any great performance car is a strong and responsive chassis. But this is not the whole story. In order to achieve optimal driveability, everything needs to work together and in tune. The engine, aero, brakes, transmission, tyres, suspension, all must create, what a race engineer would call, a completely balanced package.

In order to get the car that we wanted,

our team of engineers made over 70 modifications and upgrades to the original S60. In partnership with our long time suspension partner Öhlins, we developed bespoke shock absorbers at a technology level normally found on supercars. To produce a broader torque-band and more power, the T6 engine got a new twin-scroll turbo, a new intercooler, a full flow active exhaust system and a completely re-calibrated engine management system. The transmission was calibrated to give the driver more control. Faster gear shifts and increased driving dynamics have been

achieved through changes in the all-wheel drive system. Stopping power was optimised through a complete upgrade of the brake system, including 6-piston Brembo® brake callipers and 371mm ventilated brake discs. Add a calibrated aero package and a supportive interior and you will experience a completely balanced car. The Volvo S60 Polestar is a real driver's car made for everyday use and for all roads and conditions. Not just for that perfect sunny Sunday.



LEARNINGS FROM THE RACE TRACK

“The best cars never surprise the driver. They are predictable and consistent.”

Nowhere on earth is the traffic as intense and demanding as on the race track. The driver's attention and their responses are put to test in the most extreme of driving conditions. There are cars only inches away, all around you, and at speeds most of us will never experience, all fighting for the same ideal line in order to get to the top. The driver has to be focused on a lot of things, not only the competition. The tyre condition has to be closely monitored as well as changing track

and weather conditions, the engineer's communication over the radio and the race officials' warnings, all forcing the driver to make split-second decisions. Under these extreme conditions the driver must be able to trust the car fully. It must provide instant response and feedback on all inputs the driver makes with the steering wheel, pedals and all other instruments. The best cars never surprise the driver. They are predictable and consistent. That's why the driver wins races.

Unexpected situations will always occur. This goes for both the race track and on the open road. It's in these situations that the car must respond exactly as you as a driver expect it to. We call this driver confidence. Or as Thed Björk, one of our racing drivers puts it, “The car has to behave as I expect it to. If I have to struggle with the car, it's not part of me and I will not feel confident enough to push the car and myself to places we haven't been before. And then I can't win. Simple as that”.

IT'S AS SAFE AS ANY OTHER VOLVO

"...it's likely for you to think, that you are driving the safest road car in the world."

In 1927 the founders of Volvo, decided to make really strong cars that could cope with our rough country roads. But strength alone wasn't enough. They also had a vision – "Cars are driven by people, so the guiding principle behind everything we make at Volvo is – and must remain – safety." Our goal is that, by 2020, nobody shall be seriously injured or killed in a

new Volvo. In order to help us achieve this goal, and in keeping with our philosophy, the S60 Polestar maintains the same level of safety technologies. Add high-end racing engineering, which ensures optimised control, stopping power and responsiveness, and it's likely for you to think, that you are driving the safest road car in the world.



City Safety senses if you're about to collide with the car in front and applies the brakes. The system is active at all speeds and can reduce your speed with up to 50 km/h. In many situations, this can help you avoid collisions altogether or help to reduce the severity of a crash. As a world-first, City Safety also brakes if you're about to turn into the path of an oncoming car, again helping you to avoid or mitigate a collision.

City Safety also watches out for pedestrians and cyclists, even at night. This is particularly important as pedestrians and cyclists are much harder to see than cars in low light. Should a pedestrian or bike veer into or cross your path, City Safety brakes to avoid or mitigate a collision.

The BLIS system uses radar sensor technology to alert you to vehicles in your blind spot and to vehicles approaching fast from behind in the adjacent lane. There's also Cross Traffic Alert, which watches out for vehicles you can't see – up to 30 metres away – when you're reversing out of tight parking spaces.



Control at your fingertips

Since you'll spend a lot of your time in the driver's seat of your Volvo S60 Polestar, we've designed an interior that will put you in command. All controls are intuitively placed and easy to use.

The Adaptive Digital Display will give you all the information you need, as well as three options of background modes to choose from – Elegance, Eco, and Performance. When adjusting the display theme, the colour scheme of the centre screen changes with it.

Full sonic immersion – At Volvo, we believe you should enjoy the very best audio experience.

That's why we've designed our state-of-the-art Premium Sound with Harman Kardon®. Using 12 high-fidelity loudspeakers, the amplifier is equipped with Dirac Live®, the next generation sound enhancement software. With realistic stage sound as well as enhanced bass performance, this sound system provides an unparalleled aural experience for every passenger and connects easily with external media players.

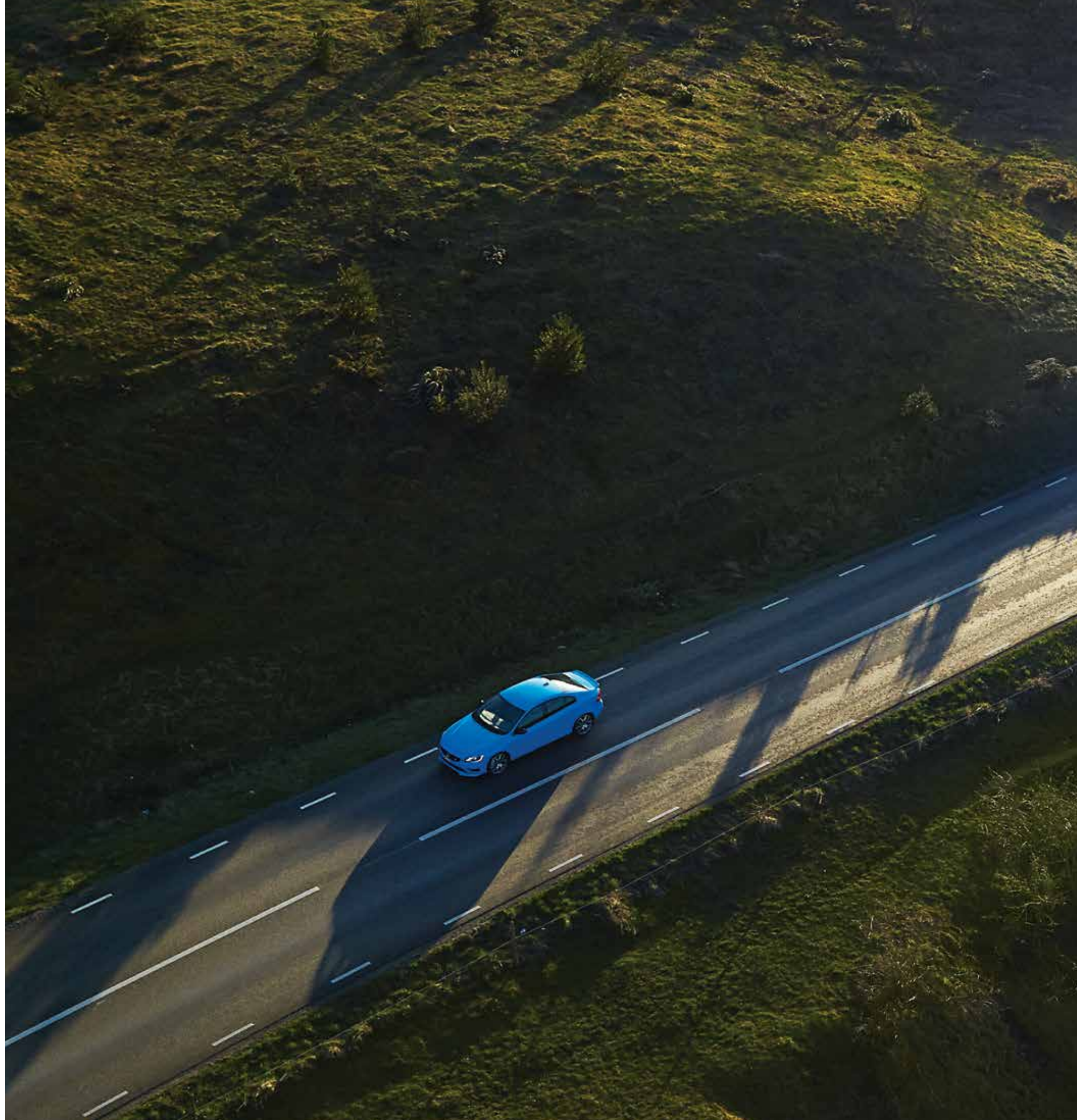



Powerful, sustainable driving, anyone?

Volvo's commitment to develop fuel efficient cars, is by default also shared by us at Polestar. Almost two decades of pushing Volvo cars to the limit (and beyond) on race tracks have given us unparalleled knowledge of how to get our car to perform at the most efficient level. We leave no stone unturned in our search for an extra horsepower or enhanced aerodynamics. This experience and knowledge has now been transferred into our S60 Polestar

car, in order to make them as powerful and efficient as possible. We have made subtle, yet very effective changes to improve the aerodynamics of the car.

The four-cylinder turbo-charged T6 engine has undergone extensive development in order to produce more power and torque, without any changes to the certified emissions ratings and fuel consumption.

Something that we are very proud of.



THE EXTERIOR

“...everything on a performance car needs to work as one in order to deliver optimal driveability.”

We've said it before, everything on a performance car needs to work as one in order to deliver optimal driveability. The exterior of the car is no exception. The carefully redesigned front splitters on

the S60 Polestar reduce the amount of airflow underneath the car and add a subtle performance look to the overall design. The same goes for the rear spoiler and diffuser, which helps increase down-force to optimise

tyre grip and control. Even the unique design of the bespoke Polestar rims is done for a reason; the airy design supports airflow around the brake system in order to increase braking endurance during hard driving.



Every component on a performance car needs to work together as one in order to create optimal driveability. The exterior of the car is no exception. For example, the bespoke lightweight Polestar rims, tested and developed in the Volvo wind tunnel, are designed to facilitate optimal airflow to ensure the best possible braking performance in all conditions.



20"

Rims: Polestar Engineered Rim ER 171-S 245/35ZR20**619**
Rebel Blue**717**
Onyx Black metallic

THE INTERIOR

“...the ergonomically sculpted seats are carefully designed to keep you gripped to your seat.”

Welcome inside. Since the S60 Polestar is for those who appreciate active driving, we created an interior that enhances the control and command active driving demands. To start, the ergonomically sculpted seats

are carefully designed to keep you gripped to your seat for increased driver support and control. The new gearshift paddles work distinctively with the six-speed gear-box, putting you in total command of your

driving. Add a nubuck clad steering wheel for maximum grip, tailor made pedals and foot rest that enhance the feedback from the road, and you are in for a great, active driving experience.



1. Nubuck /leather-clad steering wheel **UPHOLSTERIES** Nubuck Textile/perforated leather 2. Charcoal/Offblack in Anthracite Black interior with Charcoal headlining, 3S61
 3. Ergonomically Sculpted Seats 4. Gearshift Paddles 5. 8 Speed Geartronic Transmission
INLAYS 6. Carbon Fibre

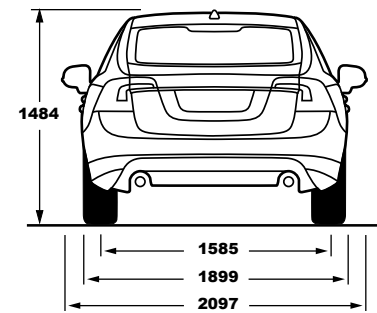
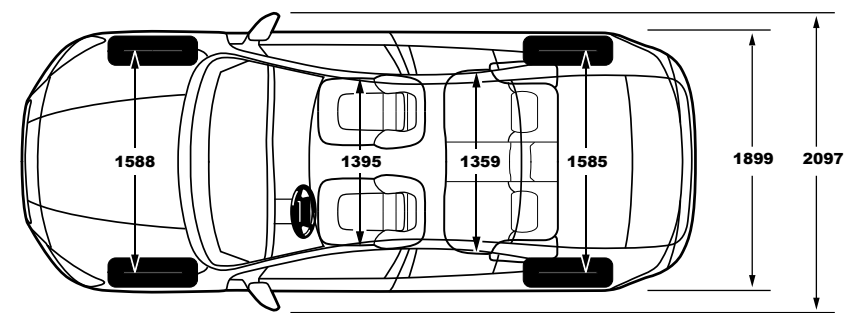
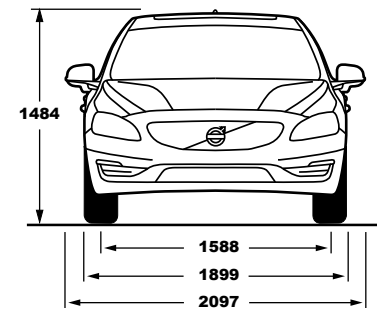
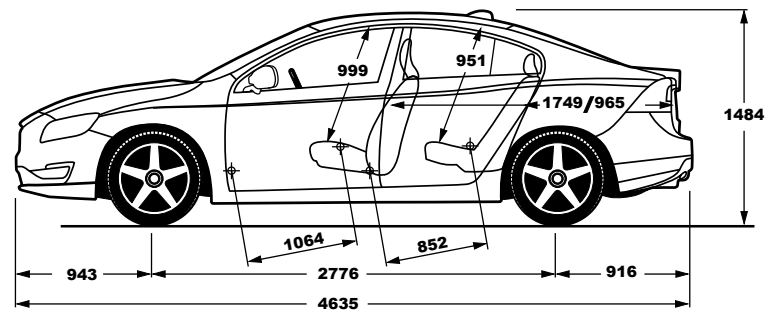

Please note: Some of the information in this brochure may be incorrect due to changes in product specifications that may have occurred since printing. Some of the equipment described or shown may now only be available at extra cost. Before ordering, please ask your Volvo Car dealer for the latest information. The manufacturer reserves the right to make changes at any time and without notice to prices, colours, materials, specifications and models.

V O L V O